



RUDRRA SENSOR

The load cell Technology

Model : PT-1

AIR-CONDITION PRESSURE TRANSMITTER

Model : RS124B-230

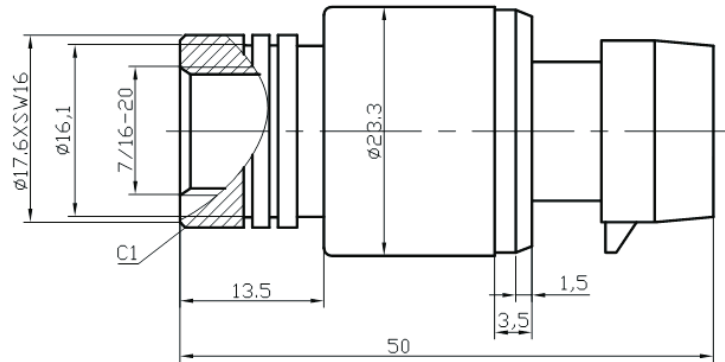

The RS124B-230 series adopts diffused silicon or ceramic piezoresistive sensor chip, with compact configuration, easy to install, and special valve pin design for lead pressure port, perfect electrical performance and long-term stability make it the idea choice for the air-condition and compressor pressure measuring and controlling.

Application

- * Laboratory test apparatus
- * Agricultural chemical equipment
- * Refrigeration and HVAC systems
- * Hydraulic pressure system
- * Gas tank pressure monitoring
- * Coolant pressure measuring

Features

- * Superior long term stability
- * Temperature compensated over wide range
- * Low power consumption
- * Excellent repeatability/Hysteresis
- * Special design for customer
- * Many OEM options

Specification

Range :	0...1bar to 0...100bar
Accuracy :	0.5%FS 1%FS : 1.5%FS
Linearity :	0.02%FS
Reliability :	0.05%FS
Output :	4-20mA, 0-5V, 0.5-4.5V, 1-5V
Input Voltage :	24(8-36V) DC:
Operation Temperature :	-10°C~125°C
Temperature Compensation :	-10 ~70 °C (Standard Compensation)
Over Pressure :	150%FS
Package material :	Brass
Electric connection :	Packed connector
Process connection :	G1/4, 1/4NPT, 1/8NPT, 7/16-20UNF(Optional)



AN ISO 9001-2008 COMPANY

RUDRRA SENSOR